

ISM

Diamond Vault



DiamondVault

The ISM DiamondVault has taken the lead in development and engineering of one of the most sophisticated six-sided burglary resistant safes manufactured in the world today. Never before has more time, experience, and expense in development of the most massive defense barriers, been molded together to form an uninterrupted, superior physical defense capability. Tried, tested and proven materials and design have made the ISM DiamondVault the new standard in the industry today.

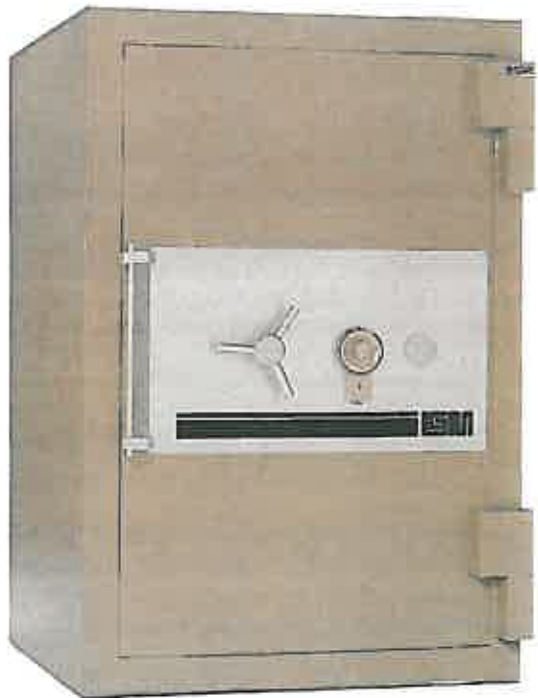

DOOR

The DiamondVault has an overall thickness of 7½" (190 mm). It is constructed of outer and inner steel plates electrically welded together and enclosing a 3" (72 mm) thick cast of alchronite, ISM's unique, superior, advanced torch and drill resisting barrier defense material. Alchronite was developed to withstand the most concentrated attacks, using the most sophisticated equipment, by burglars today. A highly torch resistant cast alloy surrounds a consistently staggered drill resistant alloy multi-grid, assuring a complete barrier with no weak points. To provide additional strength and protection against a torch attack in the door jambs, two dense frames of copper alloy are strategically incorporated into the alchronite cast.

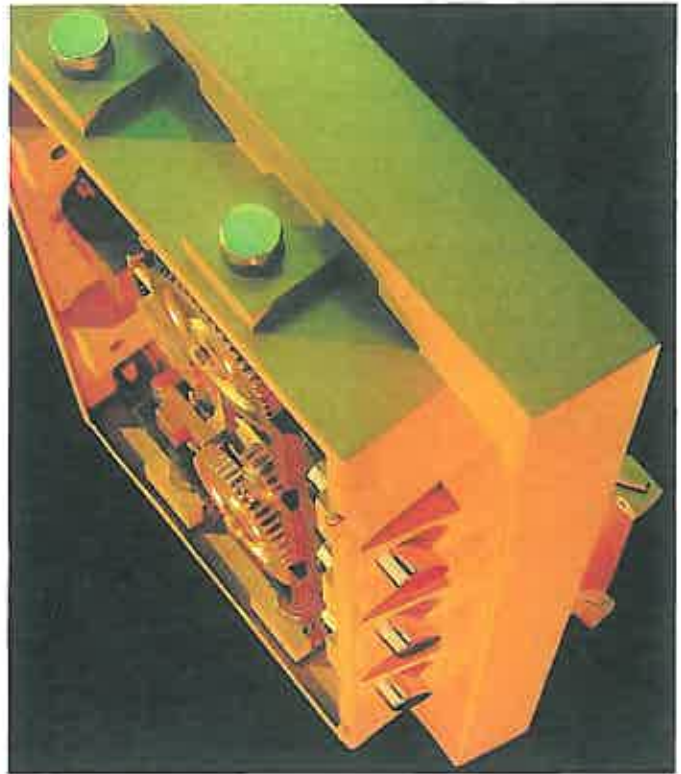

BODY

The DiamondVault body features a completely tailored one piece cast inner body of alchronite with a minimum thickness of 2" (50 mm) to a maximum boltwork protective area of 3" (75 mm). Further protection is provided against torch attack upon the boltwork chamber area by two defense frames of copper alloy in the alchronite cast. An additional outer body torch and drill resistant monolith 2¼" (55 mm) thick fills and encases multiple steel reinforcing cylinders, providing superior burglary as well as fire protection. The outer and inner bodies are encased in continuously electrically welded steel plates, making up an entire body thickness of 4¾" (120 mm).

LOCKS

The ISM DiamondVault is equipped with a maximum security Underwriters Laboratories Group I manipulation





proof combination lock. A second maximum security eight lever key lock is provided in conjunction with the combination lock. When the door of the safe is closed, it is impossible to remove the key without securing the bolts in the locked position. Even if the combination lock is not engaged, the safe is still secure.

BOLTWORK AND LOCKING MECHANISM

The DiamondVault boltwork and locking mechanism was designed to give maximum protection against not only explosive attack, but from concentrated tool attacks from all directions. Turning the capstan wheel operates a gear driven slide mechanism which engages each bolt into the alchronite bolt chamber. These massive slides move perpendicular to the bolts and provide a positive defense barrier against bolt attack. Each bolt slides through a thick solid steel block encasement. These blocks prevent the bolts from any lateral movement due to explosive or tool attack. Upon entry into the bolt chamber, each bolt is independently cross locked in the solid steel block by massive steel bars.

RELOCKING MECHANISM

All locks, including the timelock if incorporated, vital mechanism areas, and the relocking devices themselves are protected by tempered glass plates. These plates, if attacked by tools, torches or explosives, will shatter into pieces, thus activating the relocking mechanism. Each relocking bolt located far from the combination or key lock is further protected by a cross locking mechanism, which immediately freezes the relocking bolt in the locked position.

HOLDUP DETERRENT MECHANISM

The DiamondVault may be equipped, as an optional extra, with a two or three movement, 144 hour timelock that locks the safe independent of any other lock. This method of locking prevents holdups after hours. A time delay combination lock is available as an optional extra in place of the key lock. This time delay combination lock can be preset to open the safe in a specified number of minutes during business hours. Signs for both devices are affixed to the outside of the safe.

INTERIOR FITTINGS

Adjustable/removable shelves are available for setting up the safe interior to accept jewelry trays, cash trays, rolled coins, and other valuables. In each DiamondVault is an inner vault activated by a single key lock.

FINISH

A modern stainless capstan wheel and an anodized aluminum fascia panel compliment the durable paint finish, standard on all ISM Security Equipment.

INSURANCE

To achieve immediate access into the United States market, the DiamondVault was submitted to the Underwriters Laboratories for testing, and passed the most severe TRTL 30x6 test.

This label should be considered only as a point of departure when considering the superior security offered by this safe. **"WE HAVE DESIGNED AND CONSTRUCTED THE DIAMONDVAULT TO PROTECT THE PRICELESS, NOT JUST TO MEET A STANDARD"**.



DIMENSIONS AND WEIGHTS



DV 2316



DV 3521

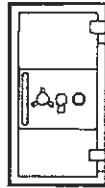

DV 4521

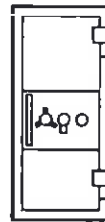

DV 5521

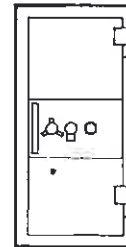

DV 6327

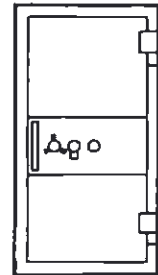

DV 7036MV

MODEL	INSIDE DIMENSIONS			OUTSIDE DIMENSIONS			CUBIC INCH CAPACITY	DOOR WEIGHT	BODY WEIGHT	APPROX. TOTAL WEIGHT
	HEIGHT	WIDTH	DEPTH	HEIGHT	WIDTH	DEPTH*				
DV 2316	23" (.584m)	16" (.407m)	16" (.407m)	33 1/4" (.845m)	25 1/4" (.654m)	27 1/2" (.699m)	5888	375 lbs. (170 kg)	1925 lbs. (874 kg)	2300 lbs. (1044 kg)
DV 3521	35" (.889m)	21" (.534m)	20" (.508m)	45 1/4" (1.150m)	30 1/4" (.781m)	31 1/8" (.794m)	14700	775 lbs. (352 kg)	2973 lbs. (1350 kg)	3750 lbs. (1701 kg)
DV 4521	45" (1.143m)	21" (.534m)	20" (.508m)	55 1/4" (1.403m)	30 1/4" (.781m)	31 1/2" (.394m)	18900	925 lbs. (419 kg)	3475 lbs. (1576 kg)	4400 lbs. (1996 kg)
DV 5521	55" (1.397m)	21" (.534m)	20" (.508m)	65 1/4" (1.657m)	30 1/4" (.781m)	31 1/2" (.394m)	23100	1250 lbs. (567 kg)	3950 lbs. (1792 kg)	5200 lbs. (2359 kg)
DV 6327	63" (1.600m)	27" (.686m)	20" (.508m)	73 1/4" (1.861m)	36 1/4" (.934m)	31 1/2" (.794m)	34020	1415 lbs. (642 kg)	4985 lbs. (2262 kg)	6400 lbs. (2903 kg)
DV 7036MV	70" (1.778m)	36" (.915m)	26" (.661m)	80 1/4" (2.039m)	45 1/4" (1.162m)	37 1/2" (.953m)	65520	1760 lbs. (799 kg)	6840 lbs. (3103 kg)	8600 lbs. (3901 kg)

*Add 2 1/2" to overall depth for handle projection.

DOOR SWING PROJECTIONS

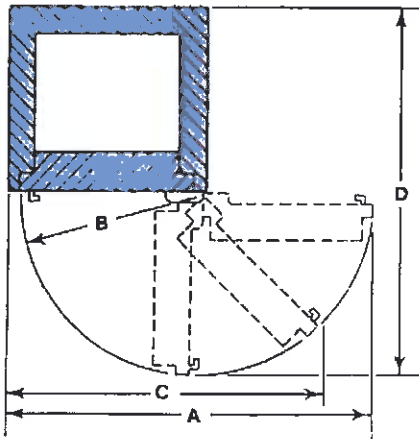

DOOR SWING DIMENSIONS

MODEL	A	B	C	D
DV 2316	48"	24 1/4"	42 1/4"	52"
DV 3521	58"	29 1/4"	46"	61"
DV 4521	58"	29 1/4"	46"	61"
DV 5521	58"	29 1/4"	46"	61"
DV 6327	70"	35 1/4"	56 1/4"	67"
DV 7036	88"	44 1/4"	70 1/2"	82"

In line with our policy always to provide the best in security, ISM reserves the right to incorporate any improvements and alter any specifications without prior notice.

LACKA SAFE

(201) 896•9200 (800) 654•5213

www.LackaSafe.com